

NX3210

GSM/GPRS/EDGE Quad-Band
CMOS Transceiver RFIC



Features

- True Quad-Band Band GSM/GPRS/EDGE Capability
- Ultra Low Power Digital Radio Architecture
- Full Support for Multi-Slot GPRS/EDGE Class 33
- Flexible Multiplexed Analog IQ Baseband Interface
- Directly Set TX and RX Frequencies Using ETSI ARFCN Words
- Ultra Low Deep-Sleep Mode Current
- Integrated Digitally Controlled Crystal Oscillator
- Integrated VCO, Synthesizer, and Loop Filter
- Digital Low-IF Receive Architecture
- Single Supply Operation from 2.7 V to 3.6 V
- Cost Effective CMOS Technology
- Industry Standard 6 mm x 6 mm QFN ROHS Compliant TQFN Package

Benefits

- Versatile GSM/GPRS/EDGE Single-Chip Solution with Flexible Analog IQ Baseband Interface
- Flexible EDGE PA Architecture Optimized for Low Cost Linear FEM Solutions
- High Level of Integration Enables Lowest Cost and Lowest Board Area Possible
- Ultra-Low Power Consumption CMOS Provides Enhanced Battery-Life

Applications

- GSM/GPRS/EDGE Quad-, Triple-, and Dual-Band Mobile Phones
- GSM/GPRS/EDGE Quad-, Triple-, and Dual-Band Data Modems
- GSM/GPRS/EDGE Quad-, Triple-, and Dual-Band Embedded Applications

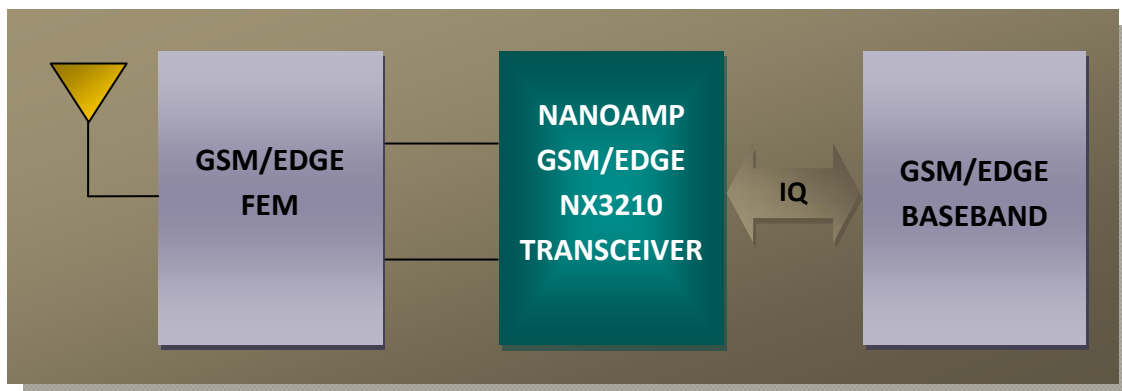

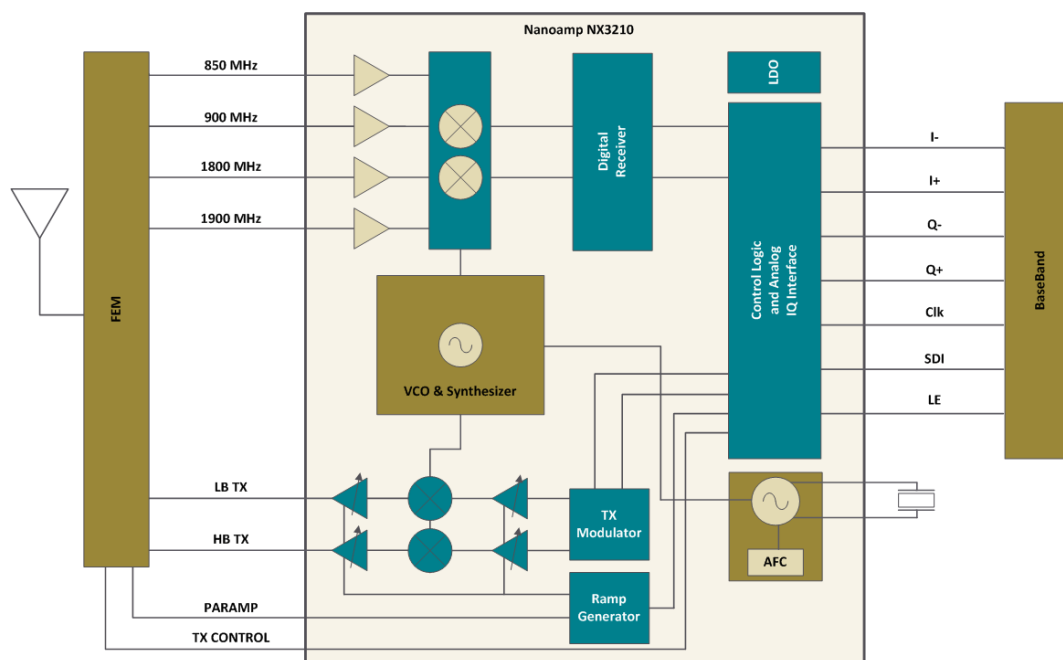

Product Description

The NanoAmp NX3210 is a quad-band CMOS GSM/GPRS/EDGE single-chip RFIC transceiver solution targeting GSM850/EGSM900 and DCS1800/PCS1900 GSM/EDGE voice and data applications. Packaged in an industry-standard 6 mm x 6 mm QFN package, the NX3210 integrates a Class 33 GSM/GPRS/EDGE transceiver with an analog IQ baseband interface to enable a flexible two-chip total radio solution.

By employing an innovative and unique CMOS architecture, the NX3210 delivers superior performance while achieving power requirements far less than similar SiGe or BiCMOS processes, thereby extending battery-life. Full integration of the transmitter, receiver, and synthesizer eliminates up to 50 external components, minimizing board area and enhancing manufacturability and calibration.

The transmitter line-up employs a novel direct-launch architecture optimized for superior GSM and EDGE performance while eliminating the need for expensive and area-consuming TX SAW filters. An integrated TX modulator and power ramp control coupled with programmable TX gain settings ensure optimized efficiency and compatibility with a broad class of PA FEM solutions. With fully integrated quad-band LNAs, the receiver line-up employs a low-IF architecture to eliminate acute issues associated with zero-IF receivers. Programmable channel-select filtering enables signal quality and RX sensitivity optimization, as well as providing compatibility with virtually all baseband ICs. The NX3210 features a synthesizer that directly accepts ARFCN words to set TX and RX frequencies. This greatly simplifies baseband interface and eliminates the need for complex synthesizer programming found in other transceiver solutions.

With a flexible baseband analog IQ interface, the NX3210 is the ideal solution to lower BOM costs, reduce board area, and increase battery-life while offering industry-leading versatility and baseband and FEM compatibility for flexible GSM/GPRS/EDGE solutions.

© 2008 NanoAmp Solutions, Inc. All rights reserved.

NanoAmp Solutions, Inc. and the NanoAmp logo are trademarks of NanoAmp Solutions, Inc. All other trademarks are the property of their respective owners. NanoAmp Solutions, Inc. ("NanoAmp") reserves the right to change or modify the information contained in this data sheet and the products described therein, without prior notice. NanoAmp does not convey any license under its patent rights nor the rights of others. Charts, drawings and schedules contained in this document are provided for illustration purposes only and they vary depending upon specific applications.

NanoAmp makes no warranty or guarantee regarding suitability of these products for any particular purpose, nor does NanoAmp assume any liability arising out of the application or use of any product or circuit described herein. NanoAmp does not authorize use of its products as critical components in any application in which the failure of the NanoAmp product may be expected to result in significant injury or death, including life support systems and critical medical instruments.

Stock No. 23304 - Rev. A 03/08