

NX3111

GSM/GPRS Quad-Band CMOS
Transceiver RFIC with DigRF Interface



Features

- True Quad-Band Band GSM/GPRS Capability
- Full DigRF 1.12 Interface Compliance
- Ultra Low Power Digital Radio Architecture
- Full Support for Multi-Slot GPRS Class 12
- Full Multi-Mode Block and Stream Support
- Directly Set TX and RX Frequencies Using ETSI ARFCN Words
- Ultra Low Deep-Sleep Mode Current
- Integrated Digitally Controlled Crystal Oscillator
- Integrated VCO, Synthesizer, and Loop Filter
- Digital Low-IF Receive Architecture
- Single Supply Operation from 2.7 V to 3.6 V
- Cost Effective CMOS Technology
- Industry Standard 6 mm x 6 mm QFN ROHS Compliant TQFN Package

Benefits

- Versatile GSM/GPRS Single-Chip Solution with Flexible DigRF Baseband Interface
- High Level of Integration Enables Lowest Cost and Lowest Board Area Possible
- Ultra-Low Power Consumption CMOS Provides Enhanced Battery-Life
- Eliminates up to 50 External Components
- No TX Saw Filters

Applications

- GSM/GPRS Quad-, Triple-, and Dual-Band Mobile Phones
- GSM/GPRS Quad-, Triple-, and Dual-Band Data Modems
- GSM/GPRS Quad-, Triple-, and Dual-Band Embedded Applications

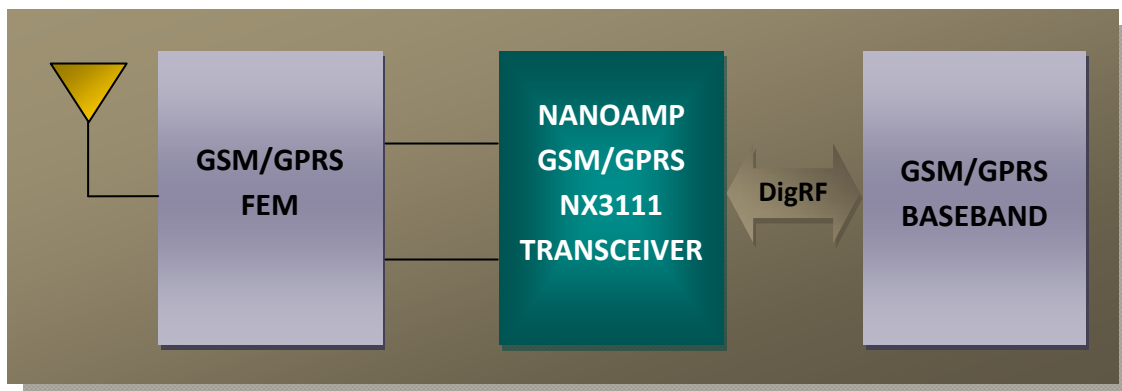

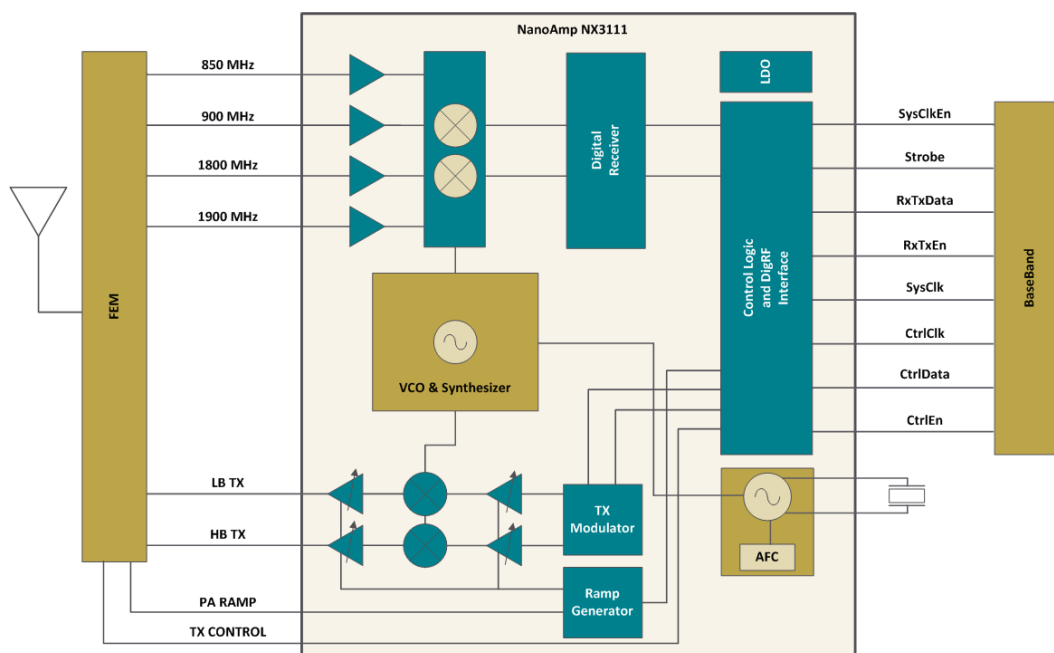

Product Description

The NanoAmp NX3111 is a quad-band CMOS GSM/GPRS single-chip RFIC transceiver solution targeting GSM850/EGSM900 and DCS1800/PCS1900 GSM/GPRS voice and data applications. Packaged in an industry-standard 6 mm x 6 mm QFN package, the NX3111 integrates a Class 12 GSM/GPRS transceiver and DigRF interface to enable a flexible two-chip total radio solution.

By employing an innovative and unique CMOS architecture, the NX3111 delivers superior performance while achieving power requirements far less than similar SiGe or BiCMOS processes, thereby extending battery-life. Full integration of the transmitter, receiver, and synthesizer eliminates up to 50 external components, minimizing board area and enhancing manufacturability and calibration.

The transmitter line-up employs a novel direct-launch architecture optimized for superior GSM and GPRS performance while eliminating the need for expensive and area-consuming TX SAW filters. An integrated TX modulator and power ramp control coupled with programmable TX gain settings ensure optimized efficiency and compatibility with a broad class of PA FEM solutions. With fully integrated quad-band LNAs, the receiver line-up employs a low-IF architecture to eliminate acute issues associated with zero-IF receivers. Programmable channel-select filtering enables signal quality and RX sensitivity optimization, as well as providing compatibility with virtually all baseband ICs. The NX3111 features a synthesizer that directly accepts ARFCN words to specify TX and RX frequencies. This greatly simplifies baseband interface and eliminates the need for complex synthesizer programming found in other transceiver solutions.

With a fully compatible DigRF interface, the NX3111 is the ideal solution to lower BOM costs, reduce board area, and increase battery-life while offering industry-leading versatility and base-band and FEM compatibility for flexible GSM/GPRS solutions.

© 2008 NanoAmp Solutions, Inc. All rights reserved.

NanoAmp Solutions, Inc. and the NanoAmp logo are trademarks of NanoAmp Solutions, Inc. All other trademarks are the property of their respective owners. NanoAmp Solutions, Inc. ("NanoAmp") reserves the right to change or modify the information contained in this data sheet and the products described therein, without prior notice. NanoAmp does not convey any license under its patent rights nor the rights of others. Charts, drawings and schedules contained in this document are provided for illustration purposes only and they vary depending upon specific applications.

NanoAmp makes no warranty or guarantee regarding suitability of these products for any particular purpose, nor does NanoAmp assume any liability arising out of the application or use of any product or circuit described herein. NanoAmp does not authorize use of its products as critical components in any application in which the failure of the NanoAmp product may be expected to result in significant injury or death, including life support systems and critical medical instruments.

Stock No. 23303 - Rev. B 03/08